

AUTOMATIC TECHNOLOGY AUSTRALIA PTY LTD

# Elite

## SWING GATE OPENER

**GatesPlus**

**1300 121 666**

**[www.gatesplus.com.au](http://www.gatesplus.com.au)**

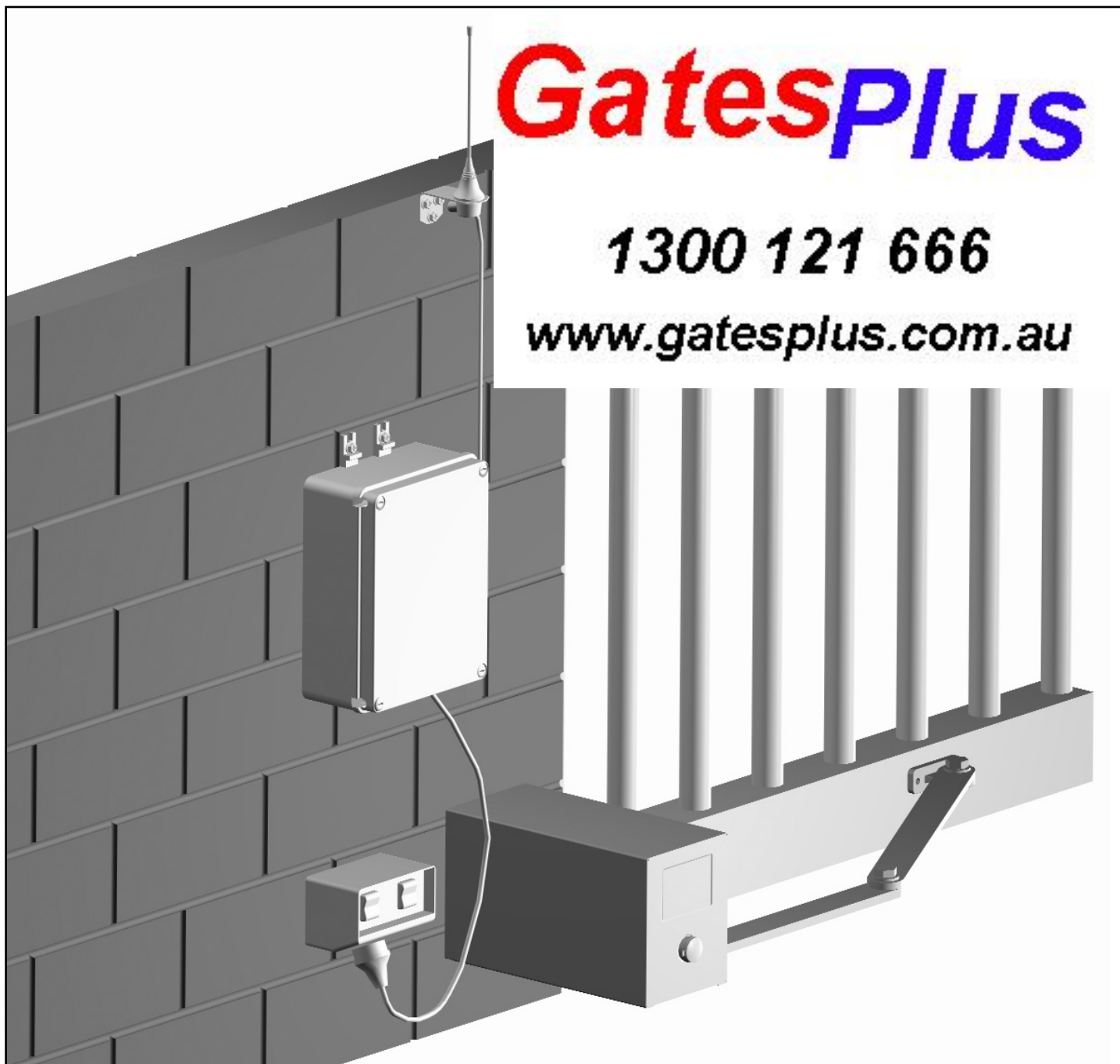

**OWNERS COPY**

**Installation Instructions**

**Warning:** It is vital for the safety of persons to follow all instructions. Failure to comply with the installation instructions and the safety warnings may result in serious personal injury and/or property and remote control opener damage.  
Please save these instructions for future reference.



# CONTENTS





















## PAGE CONTENTS

4.....	IMPORTANT SAFETY INSTRUCTIONS
5.....	FEATURES
6.....	KIT CONTENTS
7.....	DRIVE UNIT INSTALLATION
9.....	INSTALLING DRIVE UNIT ARMS
9.....	INSTALLING MINIMUM SIDE ROOM KIT
10...	MOUNTING CONTROL BOX
11...	ELECTRICAL CONNECTION - SINGLE LEAF
12...	ELECTRICAL CONNECTION - DUAL LEAF
13...	SETTING OBSTRUCTION FORCE
14...	CONTROL BOARD LAYOUT
15...	MODE SELECTION
17...	CODING TRANSMITTERS
18...	ACCESSORIES
19...	BATTERY BACK UP
19...	OPERATING INSTRUCTIONS
20...	TROUBLE SHOOTING
20...	SPECIFICATIONS
21...	PARTS LIST
22...	WARRANTY AND EXCLUSION OF LIABILITY

Automatic Technology Australia Pty Ltd to the extent that such may be lawfully excluded hereby expressly disclaims all conditions or warranties, statutory or otherwise which may be implied by laws as conditions or warranties of purchase of an Automatic Technology Australia Pty Ltd Swing Gate Opener and Automatic Technology Australia Pty Ltd hereby further expressly excludes all or any liability for any injury, damage, cost, expense or claim whatsoever suffered by any person as a result whether directly or indirectly from failure to install the Automatic Technology Australia Swing Gate Opener in accordance with these installation instructions.

# IMPORTANT SAFETY INSTRUCTIONS

**Warning - It is vital for the safety of persons to follow all instructions. Failure to comply with the following Safety Rules may result in serious personal injury and/or property damage.**

-  For **ADDITIONAL SAFETY** protection we **STRONGLY** recommend the fitting of a Photo Electric Beam. In most countries Photo Electric Beams are mandatory on all gates fitted with automatic openers. For a small additional outlay ATA recommends that Photo Electric Beams be installed with the automatic opener ensuring additional safety and peace of mind.
-  **DO NOT** operate the gate opener unless the gate is in full view and free from objects such as cars and children/people. Make sure that the gate has finished moving before entering or leaving the driveway.
-  **DO NOT** operate the gate opener when children/persons are near the gate. Children must be supervised near the gate at all times when the gate opener is in use. **SERIOUS PERSONAL INJURY** and/or property damage can result from failure to follow this warning.
-  **DO NOT** allow children to operate the gate opener. Keep the remote control away from children. **SERIOUS PERSONAL INJURY OR DAMAGE** can result from failure to follow the instructions.
-  Make sure that the **SAFETY OBSTRUCTION DETECTION** system is working correctly, and is **TESTED** every month. Test as per the Installation Instruction Manual. Adjust if necessary and recheck. Failure to follow this rule could result in **SERIOUS PERSONAL INJURY** and/or property damage.
-  **DO NOT** disengage the gate opener to manual operation with children/persons or any other objects including motor vehicle within the gateway.
-  If using a key switch or keypad or any device that can operate the gate opener, make sure it is out of reach of children and that the gateway is in full view **at all times**.
-  If the power supply cord is damaged, it **MUST** be replaced by an ATA service agent or suitably qualified person.
-  Make sure that remote controls are kept out of reach of children.
-  The opener is showerproof - it should not be immersed in water or sprayed directly by a hose or other water carrying device.
-  The gate(s) must be **WELL BALANCED**, and in good working order. Faulty gates must be repaired by a qualified technician prior to opener installation.
-  **REMOVE OR DISENGAGE** all gate locks and mechanisms prior to installation of the opener.
-  Connect the gate opener to a properly **EARTHED** general purpose 240V mains power outlet installed by a qualified electrical contractor.
-  **DISCONNECT THE POWER CORD** from mains power before making any repairs or removing covers. Only **EXPERIENCED** service personnel should remove covers from the gate opener.
-  Keep hands and loose clothing **CLEAR** of the gate and opener at all times.
-  When using auto close mode a **PHOTO ELECTRIC BEAM** must be fitted correctly and tested for operation at regular intervals. **EXTREME CAUTION** is recommended when using auto close mode. **ALL SAFETY RULES** above must be followed.
-  In order for the gate opener to **SENSE** an object obstructing the gateway, some **FORCE** must be exerted on the object. As a result the object, gate and/or person may suffer **DAMAGE or INJURY**.
-  Make sure that the gate is fully open before driving into or out of the driveway. And make sure the gate is fully closed before leaving the driveway.
-  The gate opener is not intended for use by young children or infirm persons without adequate supervision. Children should be supervised to ensure that they do not play with the remote transmitters or the opener.
-  Frequently examine the installation, in particular hinges and mountings for signs of wear, damage or imbalance. **DO NOT** use if repair or adjustment is needed since a fault in the installation or an incorrectly balanced gate may cause injury.

**PLEASE READ THIS INSTRUCTION MANUAL FULLY BEFORE ATTEMPTING TO INSTALL OR USE THE OPENER. FAILURE TO COMPLY WITH THE INSTALLATION INSTRUCTIONS MAY RESULT IN SERIOUS INJURY AND/OR PROPERTY DAMAGE.**

# FEATURES

Thank you for purchasing the ATA Elite Swing Gate Opener. This opener is designed to suit residential hinged swing gates. The components and materials used in this opener are of the latest technology and highest quality. Listed below are some of the many features.

## **DUAL LEAF GATE**

A dual leaf gate can be controlled with the addition of a second drive unit. Mains power is only required for the control box and a 5-core low voltage cable for the drive units.

## **OPERATION**

To activate the gate simply press a button on the remote control transmitter, keypad or activate any other input device such as key switch, loop detector, etc. During an open or close cycle the gate can be stopped by pressing the button while it is in motion. The next actuation will move the gate in the opposite direction.

## **HOPPING CODE TRANSMITTERS**

Every time a button pressed on the *SecuraCode*<sup>®</sup> transmitter a new access code is generated at random from over 4.29 billion combinations. This greatly enhances the security of the system and makes code “grabbing” a thing of the past.

## **SECURITY CODE STORE**

The Elite Swing Gate Opener uses state of the art technology in storing your selected transmitter codes. Up to thirty (30) transmitters can be stored in the opener’s memory.

## **ISS (INTELLIGENT SAFETY OBSTRUCTION SYSTEM)**

The opener will automatically reverse if the gate hits an obstacle or be restricted in some manner while it is performing a close cycle. The amount of force the gate should encounter before reversing is automatically adjusted by the control system during the initialisation of the automatic opener. The gate will also stop if restricted whilst opening. The Safety Obstruction Force should be checked at least once a month.

## **CONTROLLING INPUTS**

The control board has provision for ancillary controlling inputs including: open, close, stop, O/S/C, swipe, pedestrian access and photo-electric (P.E.) safety beams.

The opener can be triggered by devices such as swipe card, inductive loop detector, key switch, hard wired switch, keypad, etc.

## **PEDESTRIAN MODE**

The gate can be programmed to open partially to allow pedestrian access. In a dual leaf gate only one leaf opens to allow pedestrians through without permitting vehicle access.

## **CONTROL OF LOCK AND LIGHTS**

The incorporated controller has dedicated outputs for operating an electric lock and warning or courtesy lights (with the addition of a light relay module). The timing of these outputs can be adjusted to suit your needs.

## **PROGRAMMABLE PHOTO ELECTRIC BEAM INPUT**

The PE Beam input can be programmed to either stop or reverse the gate during a close cycle. The gate opener can also be programmed to prevent the gate moving without the PE first being triggered.

## **AUTO-CLOSE MODE**

The gate can be closed automatically after preset time. Auto-close mode can be active for full or pedestrian access or via the triggered PE input. A PE Beam must be fitted to use this function.

## **BATTERY BACKUP AND SOLAR OPERATION**

The opener can be fitted with optional battery backup or solar chargers to provide operation during power outages or at unpowered sites.

## **GATE SYNC/DELAY**

If the gate leafs overlap, a delay can be used to start one leaf moving without interfering with the other.

## **SOFT STOP**

The opener slows as the close limit is approached to reduce the chance of heavy contact and causing damage to both gate and opener.

## **MANUAL OPERATION**

The opener can be disengaged and the gate operated manually by opening the drive unit cover and disengaging the gearbox. If power to the opener is disrupted for any reason it can be disengaged. This will allow you to manually open or close the gate.

# Kit Contents

## CONTROL BOX

The control box contains the control board, capable of driving either a single or dual leaf gate, a remote control receiver and transformer. When used with suitable cable glands, it is designed to meet the IP56 weather proof rating.

## DRIVE UNIT

The Drive Unit consists of a 24V DC motor, a rugged gear box and a cam activated limit switch assembly. Each drive unit is supplied with a pair of arms, arm bracket plus arm assembly hardware.

ITEM	DESCRIPTION	QTY
1.	Drive Unit	1
2.	Control Box	1
3.	Control Box Mounting Bracket	4
4.	PTX-4 Keyring Transmitter	2
5.	Transmitter Battery	2
6.	Drive Arm Extension	1
7.	Slave Arm	1
8.	Gate Mounting Bracket	1
9.	Plastic Washer	4
10.	Shoulder Screw	2
11.	Hex. Head Screw	2
12.	Spring Washer	2
13.	Flat Washer	2
14.	Antenna (with cable & mounting bracket)	1

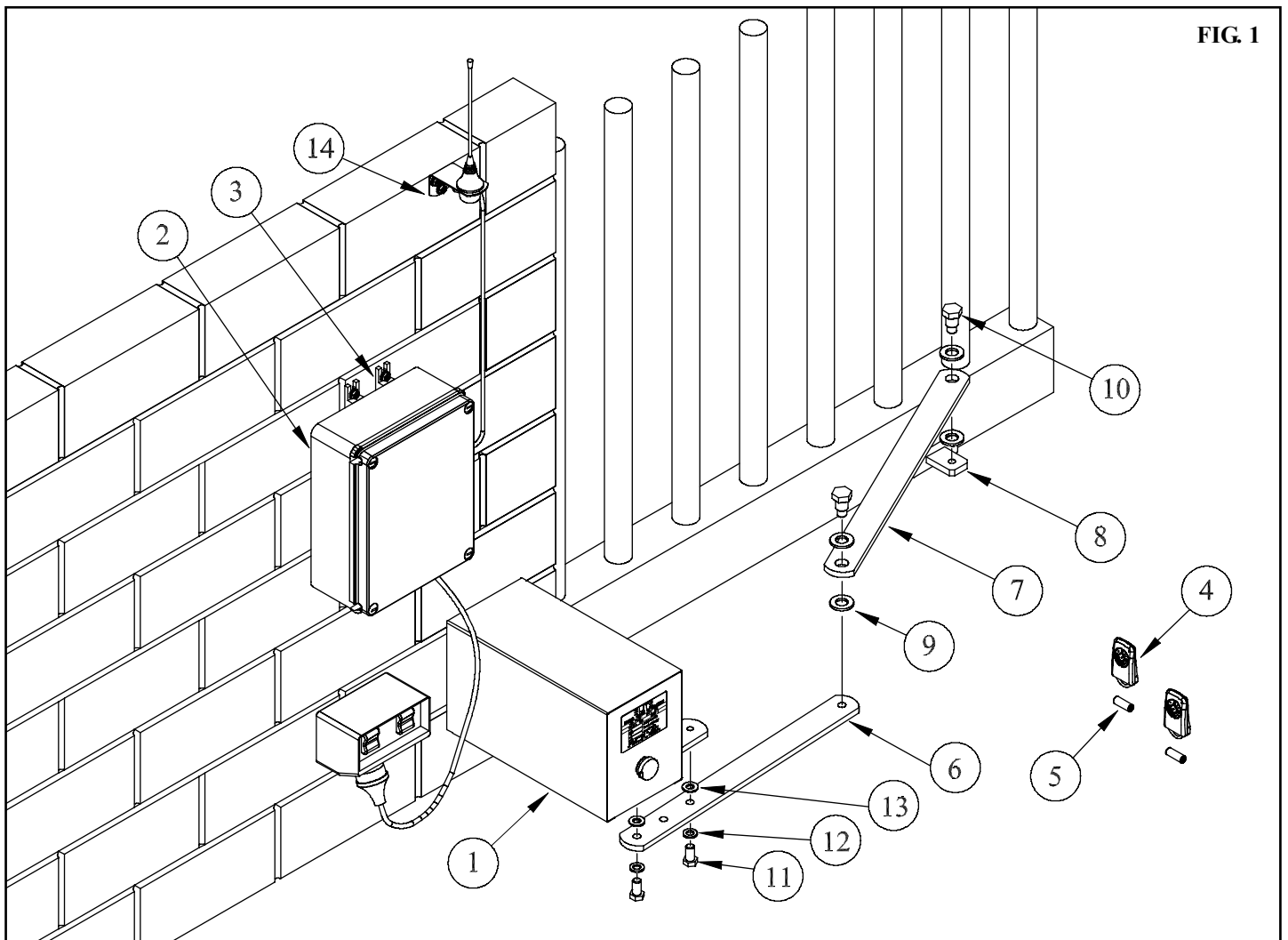

FIG. 1

# DRIVE UNIT INSTALLATION

The ATA Elite swing gate opener is designed to operate most residential swing gates. The gates must be in good working condition and should operate by hand relatively freely. Wind loading may affect the operation of the opener in high wind areas. Correct obstruction and reversing settings should be chosen for trouble free operation.

## PRE-INSTALLATION INSPECTION

Before commencing installation check the following:

1. The gate moves freely by hand for its full opening and closing travel.

2. The pier or post for mounting must be of solid construction (Brick, solid timber or steel). It must bare most of the force applied by the drive unit.
3. A weatherproof 240V 10A general purpose power point should be available within one metre of the pier/post.
4. If dual gate openers are required, provision for underground cabling should be made from one post to the other.
5. Side room clearance is adequate. Refer to Table 1 and Fig. 2. If there is not enough side room available, the Minimum Side Room Kit (Page 9) is required.
6. The mount distance of the Drive Unit should be recorded. This value will be used later.

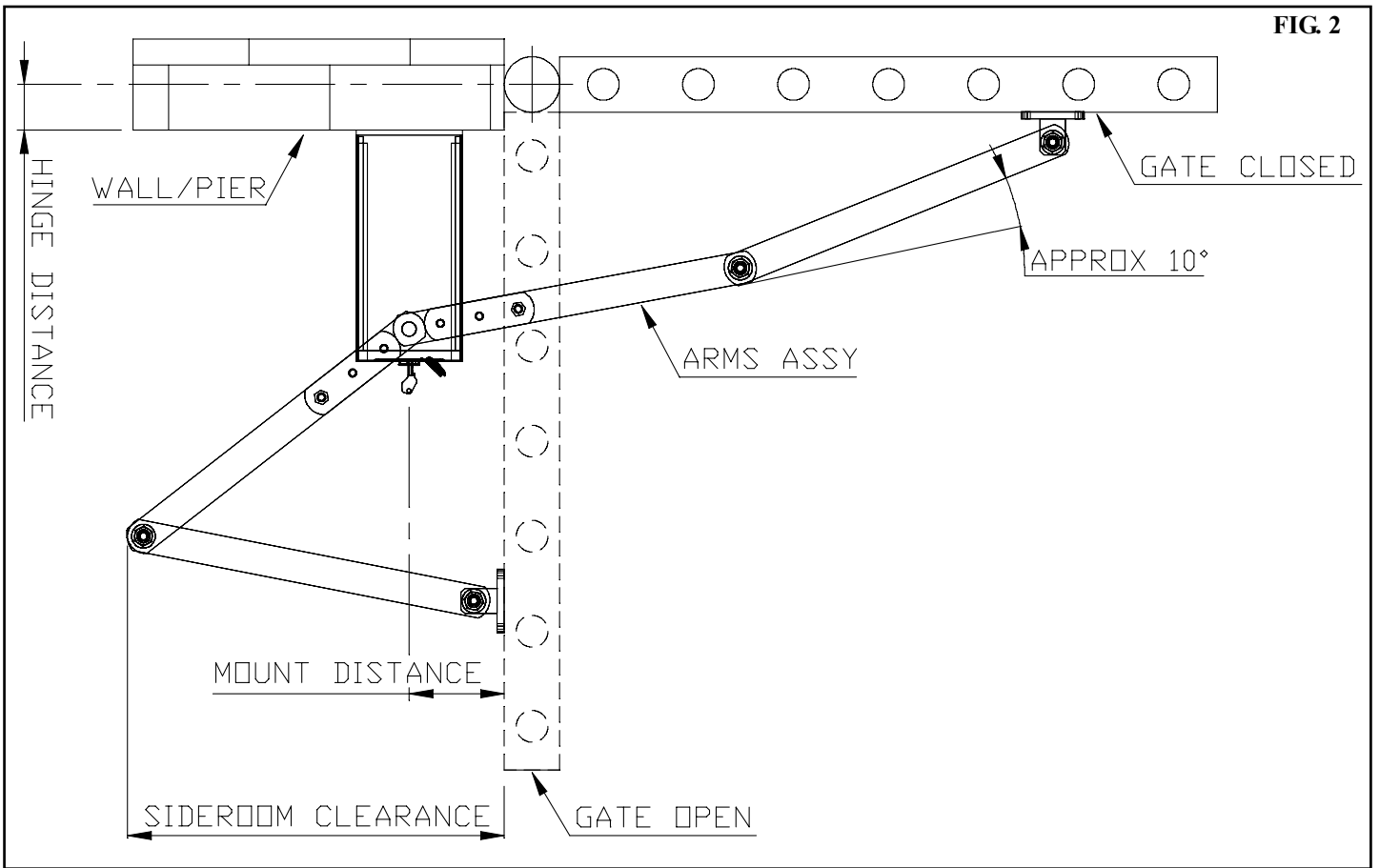

**FIG. 2**

The mount distance for the drive unit and the hinge distance for the gate can be selected to optimise the side room clearance.

**NOTE:** If the gate is already installed then measure the hinge distance and use this table to optimise the mount distance.

**TABLE 1**

MOUNT DISTANCE	HINGE DISTANCE							
	0	50	100	125	150	180	200	220
	SIDE ROOM CLEARANCE							
90	470	470	470	470	470	470	465	460
120	450	470	480	470	465	460	435	425
140	470	465	470	465	460	440	420	390
200	470	465	445	430	400	350	390	250

All dimensions are in mm

# DRIVE UNIT INSTALLATION

## MOUNTING DRIVE UNIT

1. Mount drive unit using four (4) 10mm loxins or dynabolts.
2. Make sure that the Drive Unit is mounted at an appropriate height from the ground - allow minimum 35mm clearance for drive arm extension.

**NOTE:** If the gateway slopes away from pier/post make sure an allowance is made for clearance of the drive arm extension and slave arm to not touch the ground.

## MANUAL OPERATION

Disengage drive motor by pulling manual release pin up using the release ring. While holding the ring, rotate the motor assembly clockwise. (Fig. 3 & 4)

To re-engage pull pin and rotate motor assembly anti-clockwise until manual release pin clicks into place.

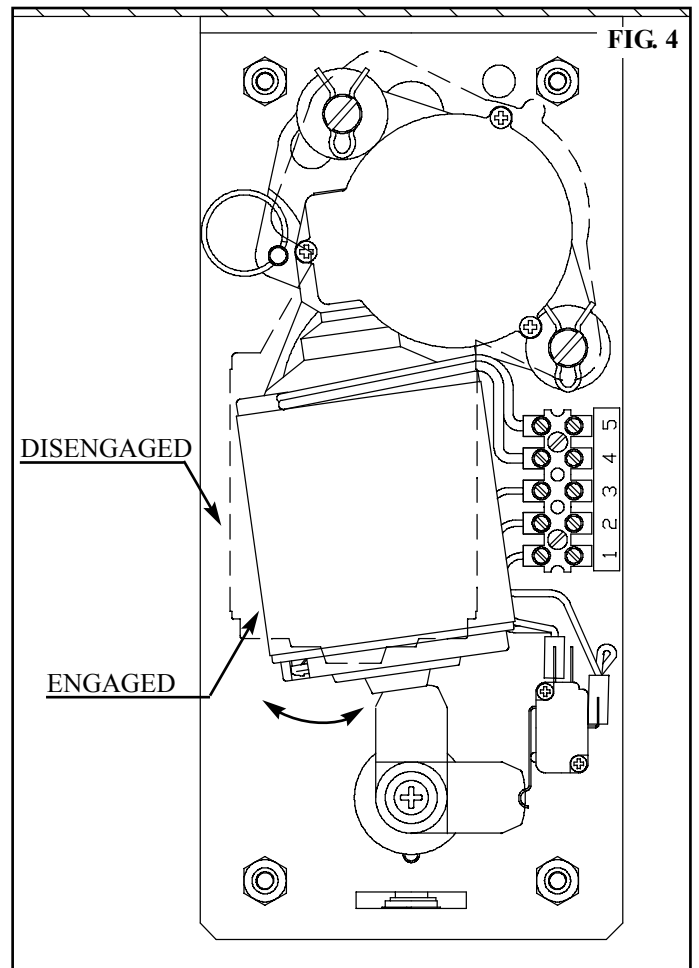
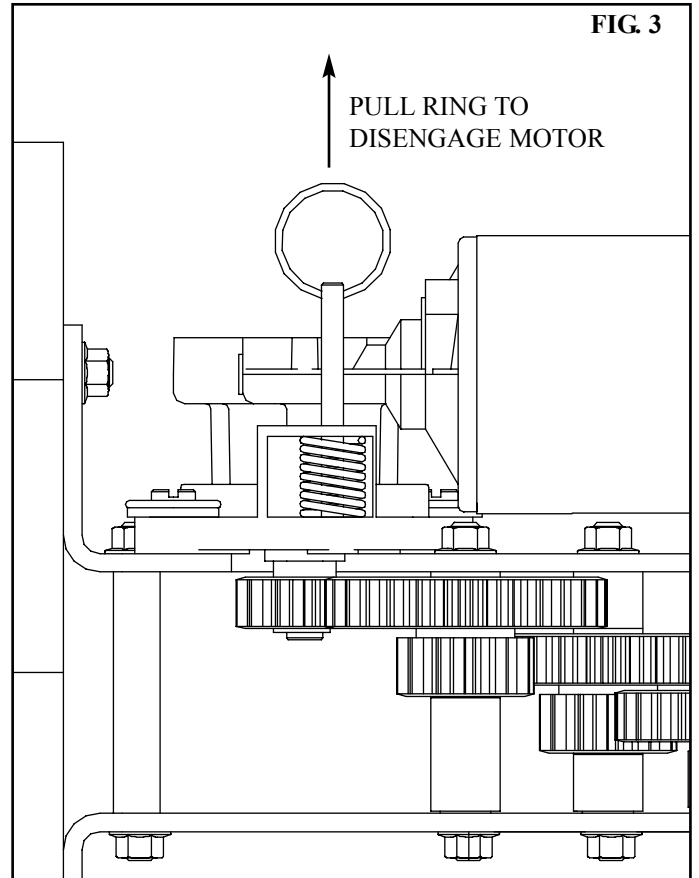



# INSTALLING DRIVE UNIT ARMS

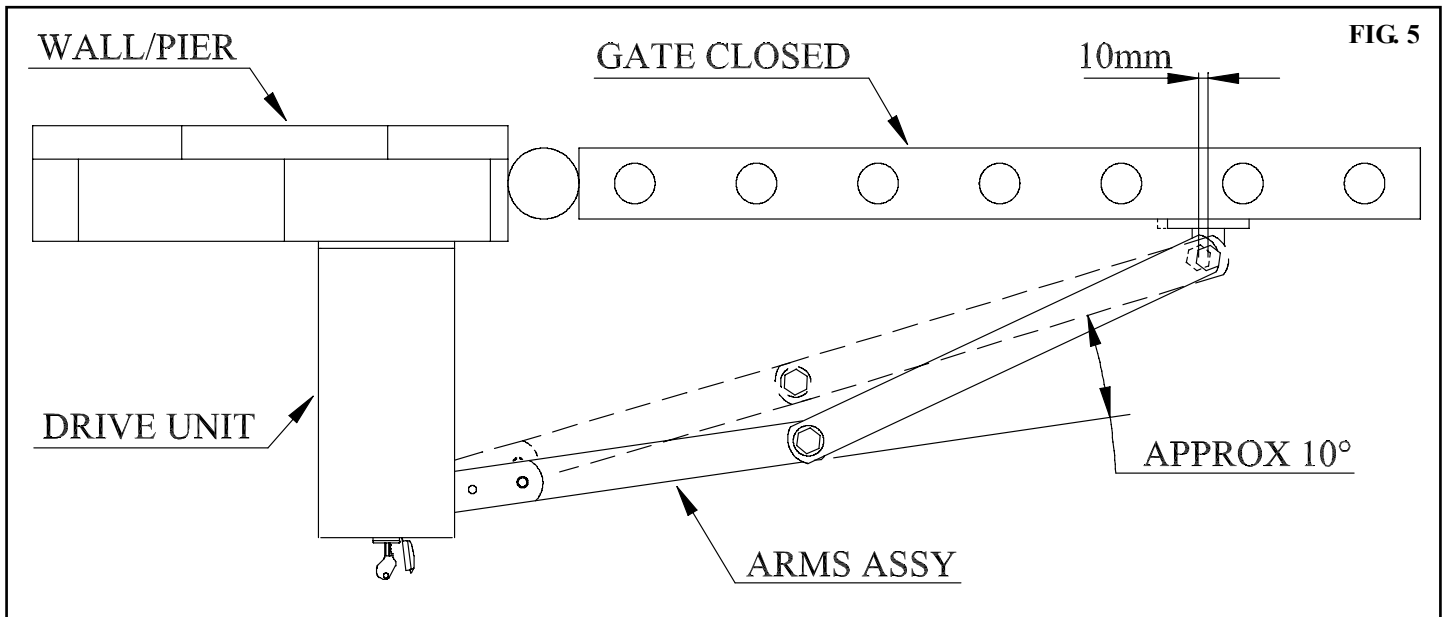

## AFFIXING ARMS AND BRACKETS TO GATE

1. Position gate in close position.
2. Attach drive arm extension to drive arm (fixed to the drive unit) (Fig. 1), using two (2) Hex. Head screws and spring and flat washers supplied.
3. Attach slave arm to drive arm extension using plastic washers and shoulder screw supplied. (see Page 6).
4. Assemble Gate Mounting Bracket and Slave Arm using shoulder screw and plastic washers, do not tighten yet.
5. Extend arms out straight and mark position where the Gate Mounting Bracket touches gate (Fig. 5).
6. From this mark, measure 10mm toward Drive Unit and mark again. This is where Gate Mounting Bracket will be mounted.
7. Remove the Gate Mounting Bracket from the Slave Arm and secure the Gate Mounting Bracket to the gate at second mark.
8. Reassemble Slave Arm to Gate Mounting Bracket using shoulder screw and plastic washers. Secure firmly.

# INSTALLING MINIMUM SIDE ROOM KIT

If you have limited side room, an optional drive arm modification kit reduces the gate opener's required side room to the width of the drive unit (135mm). (ATA Order code 90182).

## FITTING MINIMUM SIDE ROOM KIT

1. Secure the extension arm from the minimum side room kit onto drive arm extension with supplied M12 screws. Drill Ø12 hole in Drive Arm Extension (use hole in extension arm as a guide). Insert other M12 screw and secure with spring washer and nut. Check that screws are tight (Fig. 7).
2. Check that Drive Unit is **DISENGAGED AND GATE IS CLOSED**. Slide the Guide Track over idler. Locate Track on gate and check travel of the Arm. The idler should always be inside the Guide Track in the closed and open positions. Secure track to gate (weld if possible).

**NOTE:** If a shorter arm is required, drill the drive arm extension and extension arm where appropriate, you should not have to cut the arms and should still be able to use pre-threaded hole in drive arm extension.

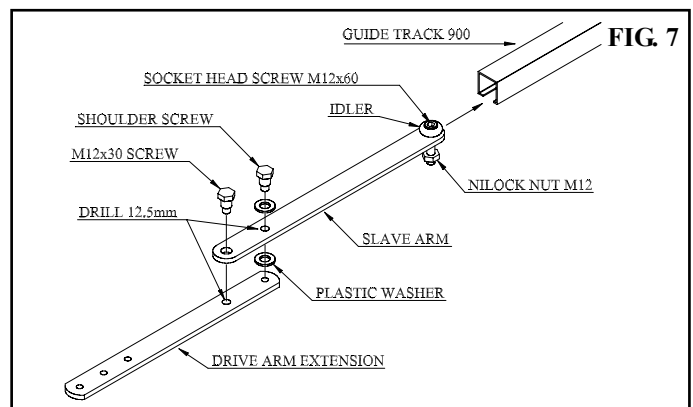
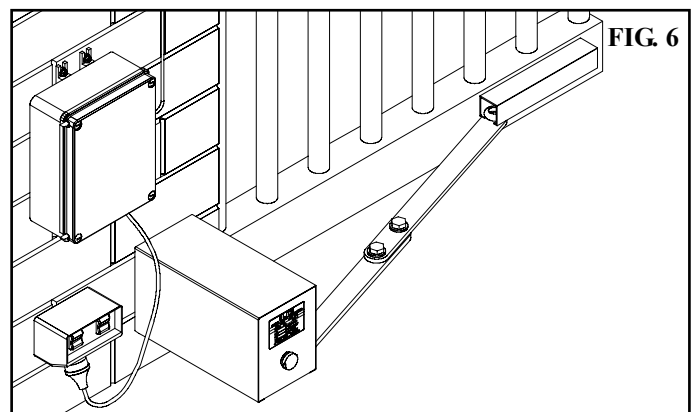

# MOUNTING CONTROL BOX

## MOUNTING CONTROL BOX

**CAUTION: DO NOT USE ANY CABLES WHICH CARRY GREEN/YELLOW WIRES AS THIS SIGNIFIES EARTH, AND DOES NOT COMPLY WITH ELECTRICAL AUTHORITY REGULATIONS.**

The control box should be mounted near the drive unit using four (4) 6mm screws.

1. Drill holes as per (Fig. 8). When locating the control box allow ample space around the unit for easy access and wiring connections.
2. Remove cover from control box.
3. Determine which leaf you would like to open first and close last. This gate leaf must be connected to Motor 1 (M1) terminals on the control board. Connect drive unit(s) to control board using 5-core cable. For detailed electrical connection (see pages 11 & 12).

**Note:** To determine left or right hand installation stand inside the driveway. looking out to the street.

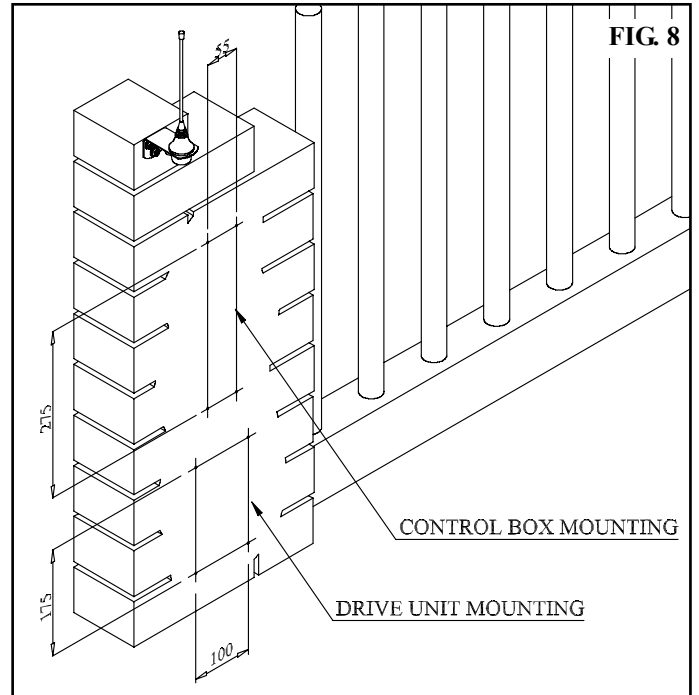

## ANTENNA

Mount the antenna at or above the height of the gate or fence for optimal reception, which ever is higher. (Fig. 8). Do not cut antenna or coaxial cable.

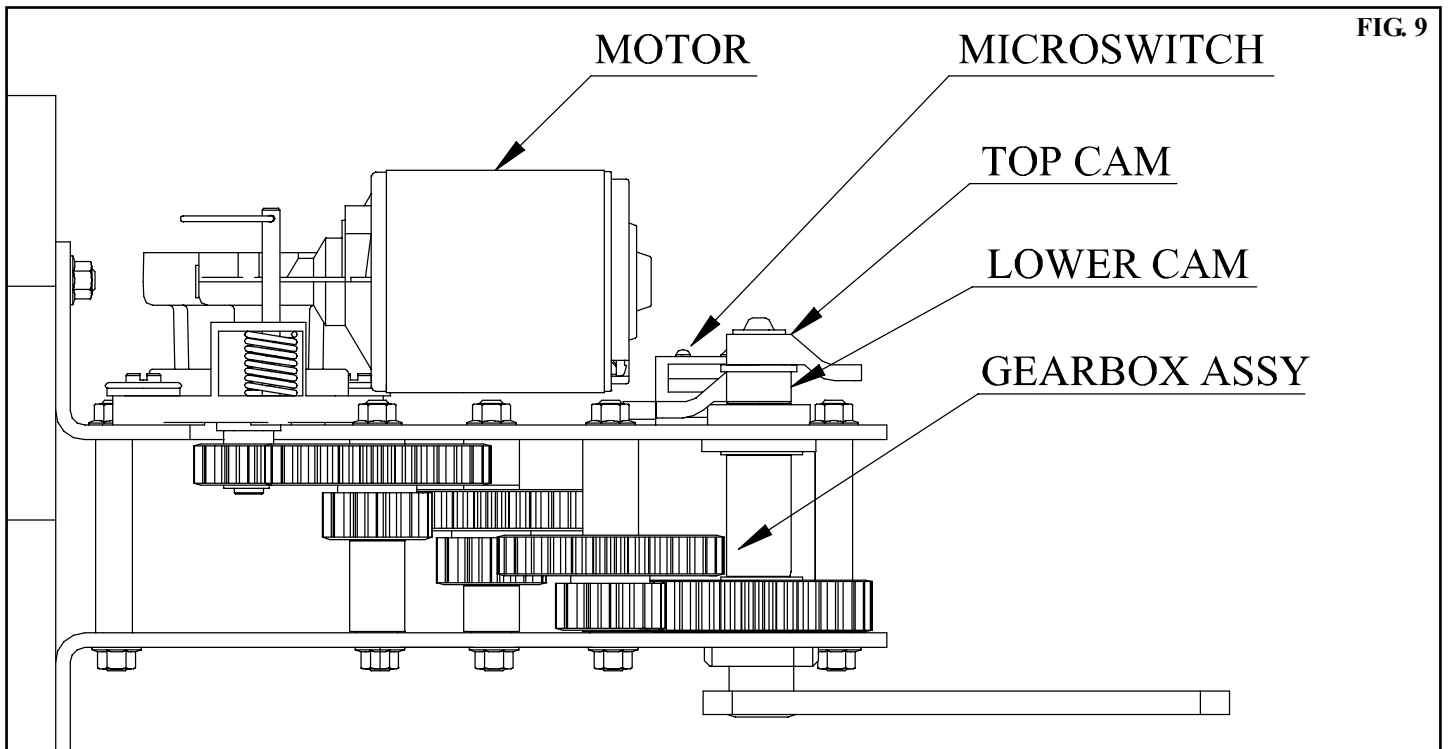

## LIMITS AND CAMS SET-UP

Setting of limits for open and closed position is performed with opener in manual position (Fig. 3 & 4).

**WARNING: DO NOT SWITCH POWER ON OR ENGAGE MOTOR DRIVE.**

For Right AND Left Hand Side installation:

1. When gate is CLOSED turn TOP cam in a clockwise direction (Fig. 9) until an audible click can be heard from the TOP micro-switch.
2. Open the gate to the required OPEN position and turn LOWER cam in an anticlockwise direction until a click can be heard from LOWER micro switch.

# ELECTRICAL CONNECTION - SINGLE LEAF

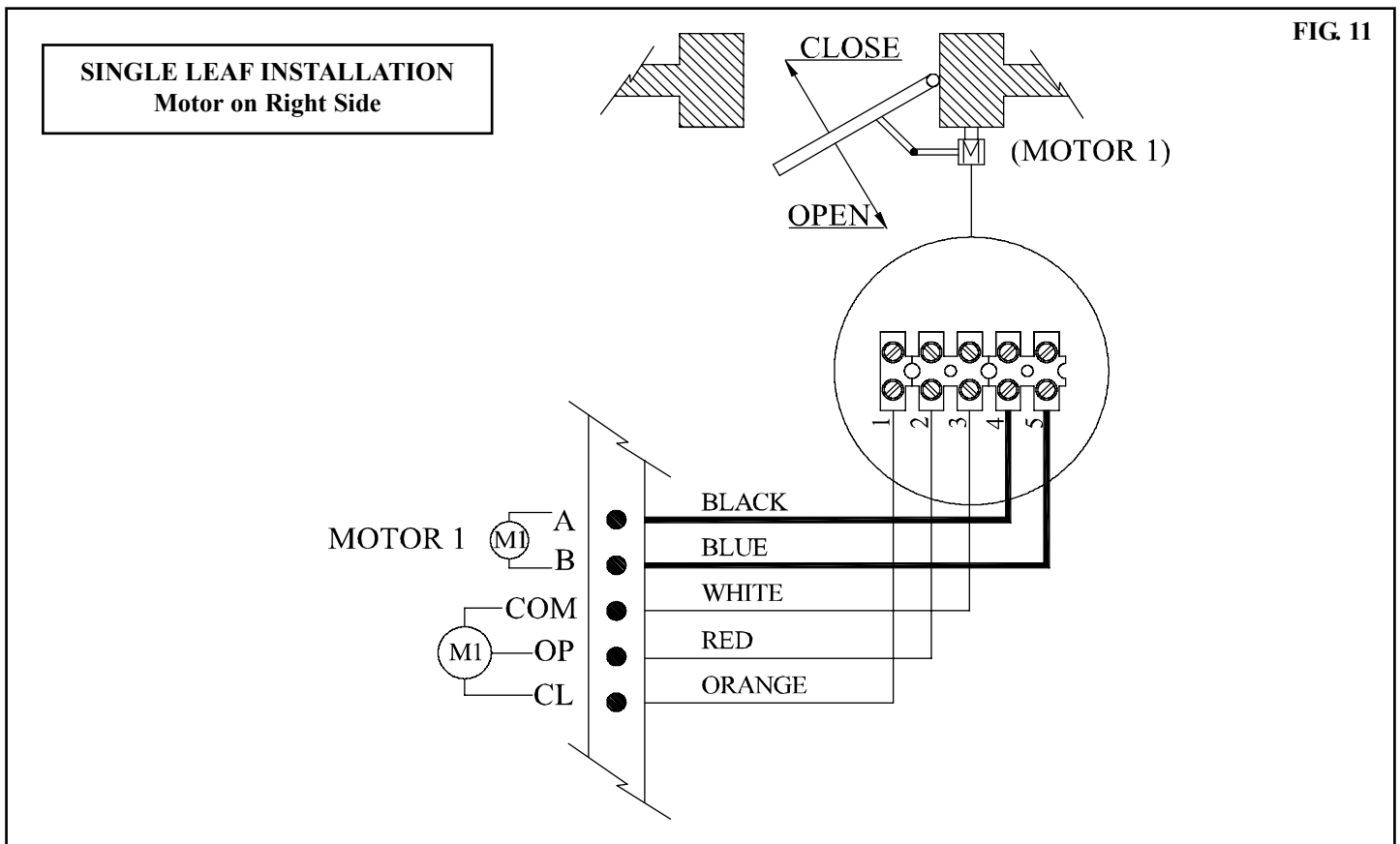
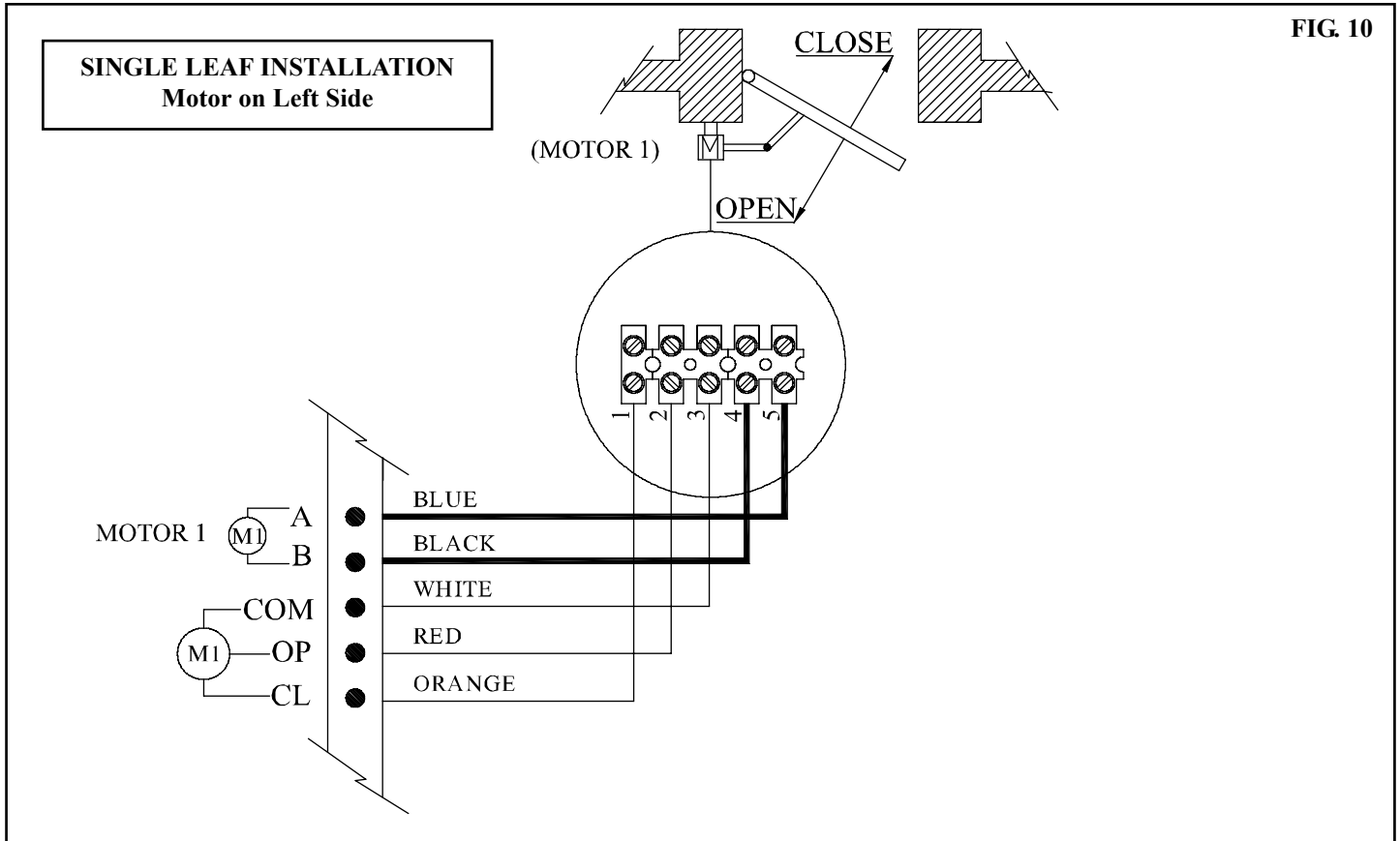

# ELECTRICAL CONNECTION - DUAL LEAF

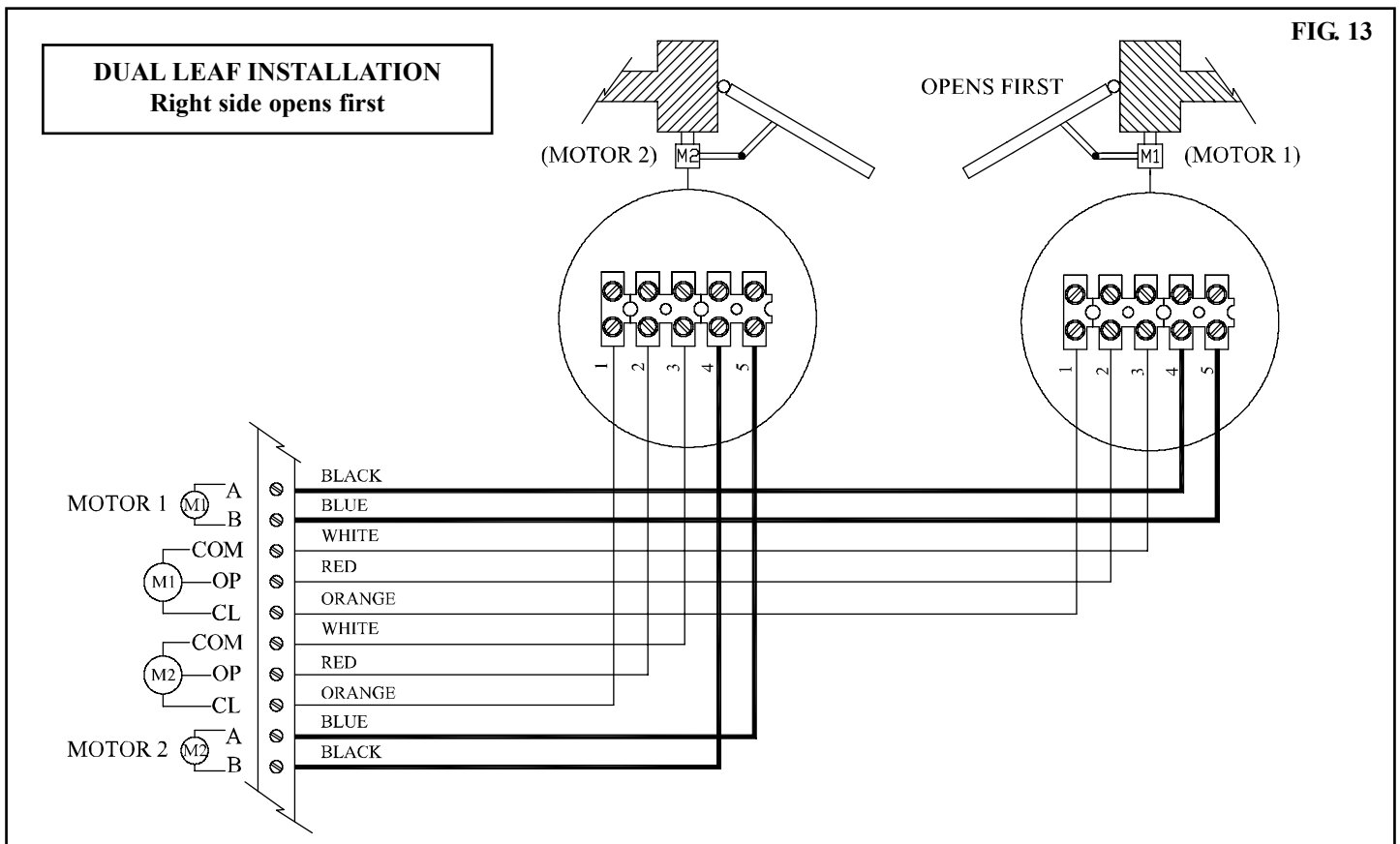
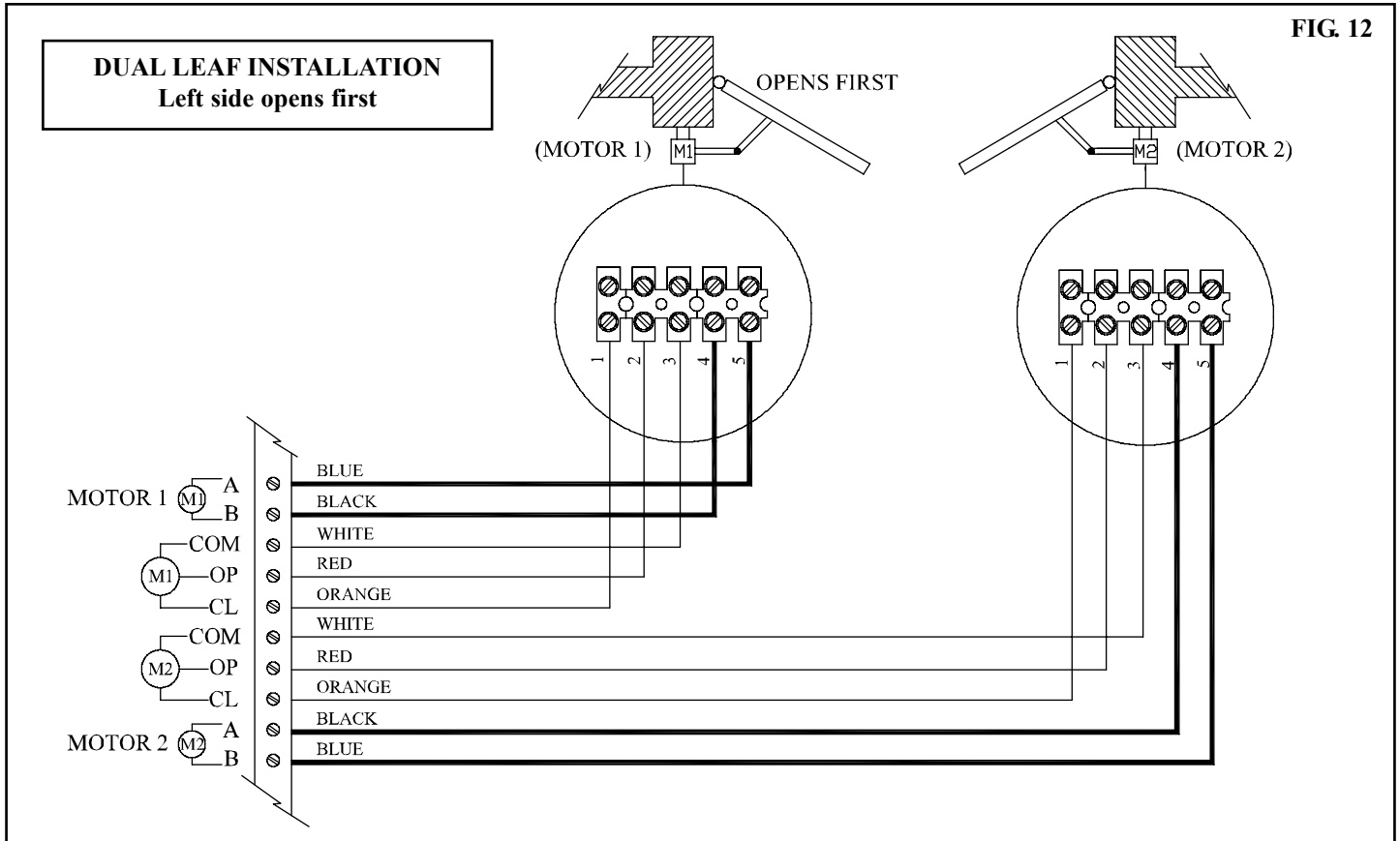

# SETTING OBSTRUCTION FORCE

## CHECKING LIMITS POSITIONS

**WARNING:** If gates require sync delay - Switch 1 must be set to ON before fine tuning limits.

1. Re-engage drive units.
2. Press OSC to move gate until the limit switch engages.
3. Fine tune limits cam positions so that the gate reaches the desired open and closed positions.

**NOTE:** In the pre-initialised state the OSC button moves the gate only while depressed.

### IMPORTANT NOTICE:

Initialising must be performed for the gates obstruction sensors to be correctly calculated and to set the soft stop feature.

## SYNCHRONISED OVERLAPPING GATE LEAFS

When dual swing gates are used it is common for a back stop to be mounted on one of the gate leafs so that the leafs are aligned when closed. To prevent the gate leafs from interfering with each other, the gate leaf with the back stop must reach the close position first when closing and open last.

Set "SYNCHRONISING DELAY" dip-switch to "ON" position. This will result in the M1 starting to open 2 seconds before M2 and M2 starting to close 2 seconds before M1.

**Note:** If a lock is to be fitted to the gate, it should be mounted on the leaf driven by M1. If the delay of 2 seconds is not suitable it can be altered, see sections SYNCHRONISING DELAY TIME. on page 16.

## INITIALISING OBSTRUCTION FORCE

**WARNING:** Make sure that the obstruction sensitivity is adjusted correctly so that, when obstructed with minimum pressure, the gate(s) reverse to the open position and stops on opening cycle.

In order for the controller to slow the motors down at the correct position and to automatically detect overloads, it needs to record the normal cycle time of each motor in each direction and also sample each motor's normal running time. If the gate(s) is stopped for some reason during step 2 below, then simply restart the process. While the open and close cycles are underway, the control board will not slow the motors and the overload detection is disabled.

## INITIALISATION

1. Engage the motor assembly (**Fig. 3 & 4**), switch power on at power point. Replace drive unit cover and lock in place.
2. Close the gate(s) if it is not already closed, by holding down the OSC button. Once the gate(s) is in the fully closed position release OSC button. The Red LED should be steady ON.
3. Press the Reset button on the control board for about two seconds then release. The gate(s) should start opening. When the gate(s) reaches the fully open position it will pause and start to close. When the gate(s) returns to the fully closed position the initialisation is complete. The controller is now ready for normal use.

**NOTE:** The OSC button is the only input which will function prior to the controller being initialised using the above procedure.

## SETTING OVERLOAD SENSITIVITY

The overload sensitivity is adjustable using the OVERLOAD dial. Position 0 making it easy to overload a motor, increasing through positions 1 to 8, with position 9 being the hardest. To set, turn the dial to the desired number to manually increase or decrease the overload sensitivity.

Standard default is - 5. Areas prone to high wind may require a slight increase.

**NOTE:** The gate will exert some force before obstruction sensing activates. Too light a setting will cause nuisance stopping when gate starts to age or resistance occurs in gate track rollers or hinges. Too heavy a setting may cause serious personal injury and/or property damage.

**WARNING:** Force adjustment must be set correctly and tested upon completion of installation. The gate should be tested periodically to ensure correct operation and adjustment made as required. The opener must not be used if force setting is incorrect or inoperative.

**NOTE:** Whenever the limit cams are adjusted the safety obstruction system must be cleared and re-initialised as travel distance may have changed.

## MOTOR SPEED CONTROL

At the start of the gate's cycle the selected motor speed is set using the SPEED dial with 0 being the slowest and 9 being the fastest. The motor will be driven at this speed until it nears the end of the travel, at which time it will be slowed down. The motor slows down to the speed represented by '3' on the speed dial.

**NOTE:** Setting the dial to 3 or lower will negate the soft stop function.

In order for the controller to determine when to slow the motors down towards the end of its cycle, a complete open and close cycle must be performed and the travel times of each motor in each direction established (i.e. initialisation).

To adjust the slow motor speed refer to page 16.

# CONTROL BOARD LAYOUT

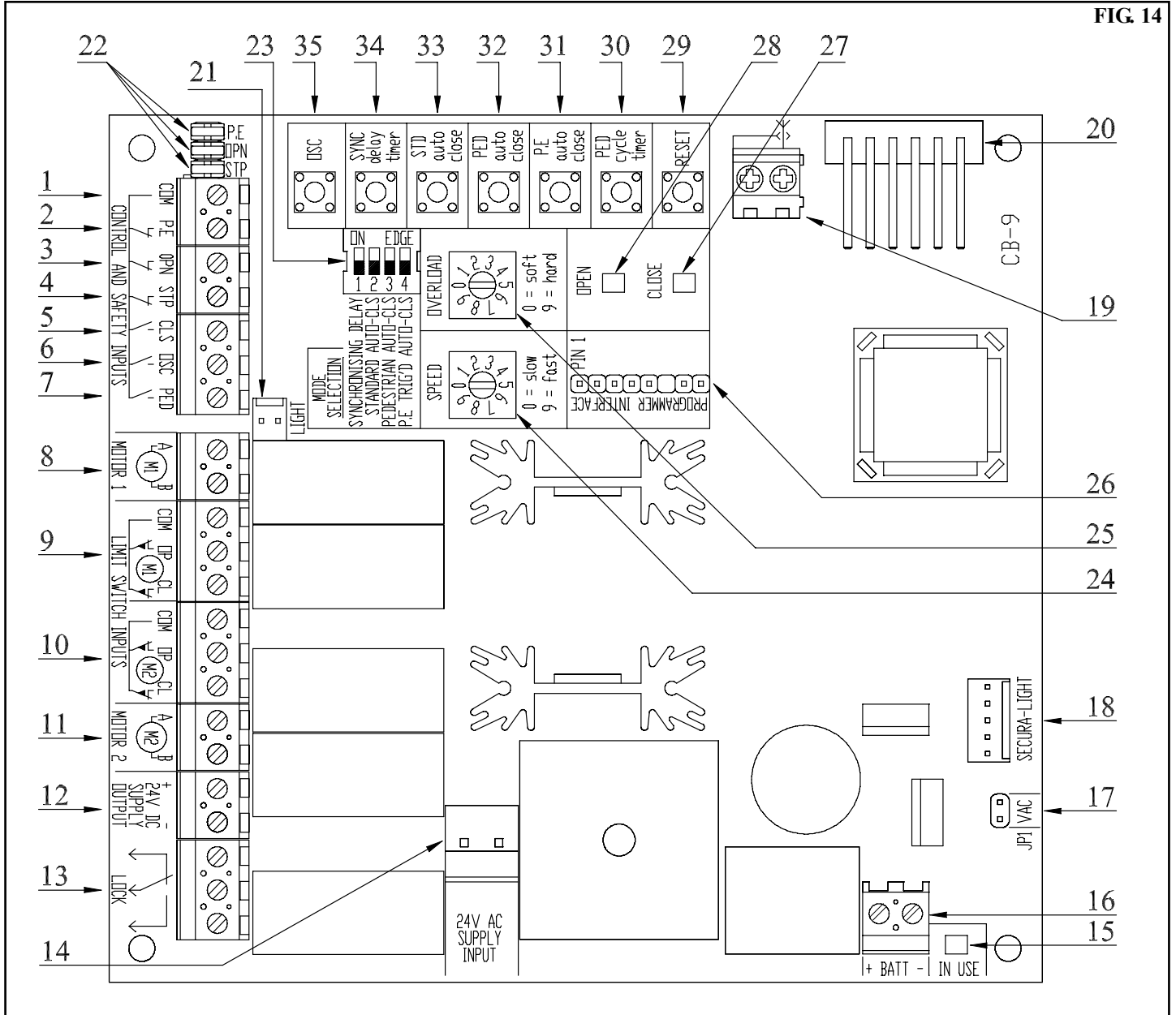

FIG. 14

1. COMMON TERMINAL FOR (2) TO (7) BELOW.
2. PHOTO-ELECTRIC SAFETY BEAM INPUT (N/C).
3. OPEN CONTROL INPUT (N/C).
4. STOP CONTROL INPUT (N/C).
5. CLOSE CONTROL INPUT (N/O).
6. OPEN/STOP/CLOSE CONTROL INPUT (N/O).
7. PEDESTRIAN ACCESS CONTROL INPUT (N/O).
8. MOTOR 1 TERMINALS.
9. MOTOR 1 LIMIT SWITCH INPUTS.
10. MOTOR 2 LIMIT SWITCH INPUTS.
11. MOTOR 2 TERMINALS.
12. 24V DC SUPPLY OUTPUT (TO ACCESSORIES).
13. ELECTRIC LOCK CONTROL TERMINALS.
14. 24V AC SUPPLY INPUT (FROM TRANSFORMER).
15. BACKUP BATTERY SUPPLY IN USE L.E.D.
16. BACKUP BATTERY TERMINALS.
17. VACATION SHUNT & PINS.
18. SECURA-LIGHT INTERFACE CONNECTOR.
19. ANTENNA (ONLY USED WITH 27MHz RECEIVER).
20. PLUG-IN RECEIVER CONNECTOR.
21. LIGHT RELAY INTERFACE CONNECTOR.
22. P.E., OPN, STP SHUNTS.
23. MODE SELECTION DIPSWITCHES.
24. SPEED SELECTION DIAL.
25. MOTOR OVERLOAD SENSITIVITY DIAL.
26. PROGRAMMER INTERFACE CONNECTOR.
27. CLOSE STATUS LED.
28. OPEN STATUS LED.
29. RESET BUTTON.
30. PEDESTRIAN ACCESS CYCLE TIMER SET BUTTON.
31. P.E. AUTO-CLOSE TIME SET BUTTON.
32. PEDESTRIAN AUTO-CLOSE TIME SET BUTTON.
33. STANDARD AUTO-CLOSE TIME SET BUTTON.
34. SYNCHRONISING DELAY TIME SET BUTTON.
35. OSC - OPEN/STOP/CLOSE BUTTON.

# MODE SELECTION

## AUTO-CLOSE MODE

Auto-close mode automatically closes the gate after a preset time once the gate has reached its desired open position. The controller starts to close the gate when the count down has expired. The timer can be suspended by activating a suspending input (which inputs 'suspend' depends on which auto-close mode is selected).

When the input is deactivated the auto-close timer is reset and the count down recommenced. Auto-close functions are temporarily disabled by certain actions. When this happens the controller will not auto-close the gate until the user performs some action to re-enable the function. Details about the three auto-close modes follow.

### STANDARD AUTO-CLOSE

This mode is selected by placing the mode selection switch labeled "STANDARD AUTO-CLS" into the "ON" position. When selected the gate will auto-close 30 seconds after being fully opened. The following gives details about this auto-close mode.

#### Auto-closes after being:

- Fully opened. (except when the gate is reversed to the open position after a motor overload is detected while closing)

#### Countdown suspended by:

- The P.E. input being active.
- The OPN input being active.

#### Function temporarily disabled by:

- Activating the STP input while the gate is open.
- A motor overload causing the gate to reverse open.

#### Function re-enabled by:

- Activating the OPN input while the gate is open.
- Activating the OSC input, in SWIPE mode, while the gate is open.
- By activating any input which causes the gate leaf to start to close. The auto-close function will then be enabled once the gate is re-opened.

The standard delay time of 30 seconds can be altered, see STANDARD AUTO-CLOSE DELAY TIME, on page 16.

### PEDESTRIAN ACCESS AUTO-CLOSE.

This mode is selected by placing the mode selection dip-switch labeled "PEDESTRIAN AUTO-CLS" into the "ON" position. When selected, the gate leaf will auto-close 15 seconds after being opened for pedestrian access.

#### Auto-closes after being:

- Driven to the programmed pedestrian access position. (Except when the gate leaf is reversed after a motor overload is detected.) Reversing during pedestrian access is only implemented when special PED modes are selected.

- Stopped by the P.E. input when closing after pedestrian access (standard PED mode only).

#### Countdown suspended by:

- The P.E. input being active.
- The PED input being active.

#### Function temporarily disabled by:

- Activating the STP input while the gate leaf is in the programmed pedestrian access position.
- Activating the STP input in condition 2 of 'Auto-closes after being above.'
- A motor overload causing the gate to reverse back to the programmed pedestrian access position. (Reversing during pedestrian access is only implemented when special PED modes are selected.)

#### Function re-enabled by:

- Activating the PED input, in SWIPE mode, while the gate is in the programmed pedestrian access position. Activating the PED input and causing the gate leaf to start to close.

The standard delay time of 15 seconds can be altered, see section PEDESTRIAN ACCESS AUTO-CLOSE DELAY TIME on page 16.

### P.E TRIGGERED AUTO-CLOSE

This mode is selected by placing the mode selection dip-switch labeled "P.E. TRIGGERED AUTO CLS" into the "ON" position. When this auto-close mode is selected, the gate will auto-close after the P.E. input has been activated and released since:

1. The gate was last closed
2. The P.E. triggered auto-close function was re-enabled after being disabled.
3. The SWIPE input was activated.

#### Auto-closes after the P.E. input has been activated and then released and the gate:

- Is fully opened. (except when the gate is reversed to the open position after a motor overload is detected while closing).
- The gate has been stopped by the P.E. input.

#### Countdown suspended by:

- The P.E. input being active.
- The OPN input being active.

#### Function temporarily disabled by:

- Activating the STP input.
- A motor overload causing the gate to stop or reverse open.

#### Function re-enabled by:

- Activating the OPN input while the gate is open.
- Activating the SWIPE input.
- By activating any input which causes the gate to start to open or close. The auto-close function will then be enabled once the gate is re-opened or the P.E. input causes the gate to stop.

# MODE SELECTION

If the P.E. input is configured to stop the gate during opening or closing, then the gate can auto-close from a midway position. This feature is implemented so that once a vehicle has entered the gateway and broken the P.E. beam, the gate will stop. When the P.E. beam is cleared the gate will auto-close from the stopped position. This results in the gate not having to fully open and thus reducing the time unwarranted access through the gate is possible. The factory set delay time of 1 second is adjustable, see section "P.E. TRIGGERED AUTO-CLOSE DELAY TIME" below.

## MIXING AUTO-CLOSE MODES

The PEDESTRIAN AUTO-CLS mode and the STANDARD AUTO-CLS mode do not affect each other as one operates during standard operation and the other during pedestrian access. However it is possible to have P.E. triggered pedestrian auto-close by selecting both the PEDESTRIAN AUTO-CLS and P.E.

TRIGGERED AUTO-CLS modes. In this case the gate would partly open for pedestrian access and then either the P.E. TRIGGERED AUTO-CLS would cause the gate to auto-close when a pedestrian walks through and activates the P.E. beam or, if no one walked through the PEDESTRIAN AUTO-CLS would close the gate. This way the gate is only kept open long enough for a person to walk through, but with the backup that if no one walks through the gate will still close. The same concept can be used with standard operation by selecting both the STANDARD AUTO-CLS and the P.E. TRIGGERED AUTO-CLS modes. That is, the gate would only stay open long enough for the vehicle to pass through but would still auto-close if no vehicle enters.

**Note:** P.E. TRIGGERED AUTO-CLS will not operate during pedestrian access unless the PEDESTRIAN AUTO-CLS mode is also selected.

# MODE SETTING ADJUSTMENT

This section describes how to adjust several parameters via the control boards buttons and dials. Other adjustments can be performed by use of the advanced technicians Control Board Instruction Manual and Programmer. Contact your local ATA dealer for a copy.

## SYNCHRONISING DELAY TIME

The synchronising delay time is adjusted using the 'SYNC delay timer' button. The synchronising delay time is adjustable in 0.1 second steps. The factory set default is 2 seconds.

## STANDARD AUTO-CLOSE DELAY TIME

The standard auto-close delay time is adjusted using the 'STD auto-close' button. Delay time is adjustable in 1 second steps. The factory set default is 30 seconds.

## PEDESTRIAN ACCESS AUTO-CLOSE DELAY TIME

The pedestrian auto-close delay time is adjusted using the 'PED auto-close' button. Delay time is adjustable in 1 second steps. The factory set default is 15 seconds.

## P.E. TRIGGERED AUTO-CLOSE DELAY TIME

The P.E. triggered auto-close delay time is adjusted using the 'P.E. auto-close' button. Delay time is adjustable in 1 second steps. The factory set default is "off".

## PEDESTRIAN ACCESS CYCLE TIME

The pedestrian access cycle time sets how far gate leaf 1 opens for pedestrian access.

1. Drive the gate to the closed position using the OSC button or another control input.
2. Press and hold the 'PED cycle timer' button. The gate leaf driven by motor 1 will start to open.

3. When the gate leaf has reached a position suitable for pedestrian access, release the button.
4. The pedestrian access drive timer has now been set. Either press the OSC button and exit the time set mode or continue setting one of the synchronising delay or auto-close times.

## SLOW MOTOR SPEED

**IMPORTANT:** Please make sure that the gate(s) are in the open position before proceeding with steps 1 to 5 below.

The speed the motor slows down towards the end of a cycle can be adjusted using the following procedure. The factory set default slow speed is set to "3"

1. Note the current maximum speed selected by the speed selection dial.
2. Using the speed selection dial select the desired slow speed.
3. Press and hold the 'RESET' button and count five (5) flashes of the OPEN status led.
4. Release button.
5. Place the speed selection dial back to the desired maximum speed .

## ADJUSTING AUTO-CLOSE AND SYNC DELAY TIMES

1. Press and hold the required button for the desired time.
2. Release button.
3. Press the OSC button to exit the time setting mode or restart from step 1 to set another time.

### Notes:

- a) The time setting mode is indicated by both the OPEN and CLOSE status LED's being off.
- b) Each flash of the OPN led represents 1 second.
- c) When a button is first pressed, the CLOSE status LED turns on. The time delay is set to zero when the CLOSE LED turns off and then increases for as long as the button is held.



# CODING TRANSMITTERS

## CODING TRANSMITTERS INTO RECEIVER

Transmitters can be programmed into the gates receiver to do two functions: the full **Open/Stop/Close** cycle, and partly open gate for **PEDE**strian access. The memory in the receiver can store up to 30 different remote control transmitters.

**Note:** Make sure to connect the battery to the transmitter in the correct polarity.

### STORING TRANSMITTER CODE FOR O/S/C

1. Press and hold the SW1 button on the receiver (**Fig. 15**).
2. Press the button on the transmitter you would like to use to control the gate for approximately two seconds.
3. Release. Pause for two seconds. Press the same button again on the transmitter for approximately two seconds.
4. Release the SW1 button.
5. Press the transmitter button to test if it operates the gate.

**Note:** If required, all four transmitter buttons can be coded to do the same function.

### STORING TRANSMITTER CODE FOR PED ACCESS

1. Press and hold the SW2 button on the receiver (**Fig. 15**).
2. Press the button on the transmitter you would like to use to control the pedestrian access for approximately two seconds.
3. Release. Pause for two seconds. Press the same button again on the Transmitter for approximately two seconds.
4. Release the SW2 button.
5. Press the Transmitter button to see if it operates the gate.

**IMPORTANT:** The Pedestrian Access Cycle Time must be set to activate this feature.

### STORING ADDITIONAL TRANSMITTER(S) FROM A REMOTE LOCATION

Using this method you do not need to have direct access to the control box or receiver. However, you do need a transmitter that is already coded to the controller's receiver.

**NOTE:** The gate must be activated when the step below is performed. The moving gate confirms that the correct button was pressed and the transmitter is in range of the opener.

1. Press the button on a pre coded transmitter and release (**Fig. 16**).
2. Using a small pin press and hold the coding hole for 2 seconds (**Fig. 17**).
3. Within 10 seconds press the button on the new transmitter for approximately two seconds (**Fig. 18**).
4. Release. Pause for two seconds. Press the same button again for approximately two seconds.
5. Wait ten seconds and test to confirm that coding was successful.

### DELETING STORED TRANSMITTER CODES TO DELETE ONE TRANSMITTER

1. Press and hold the SW1 button on the receiver. (Pressing SW2 button will only delete PED function and not OSC for that transmitter).
2. Press the button (one of four) on the transmitter you would like to delete from the receiver for two seconds.
3. Pause for two seconds. Press the same button again 2 secs.
4. Release the SW1 button.
5. Press transmitter button to confirm it does not operate the gate.

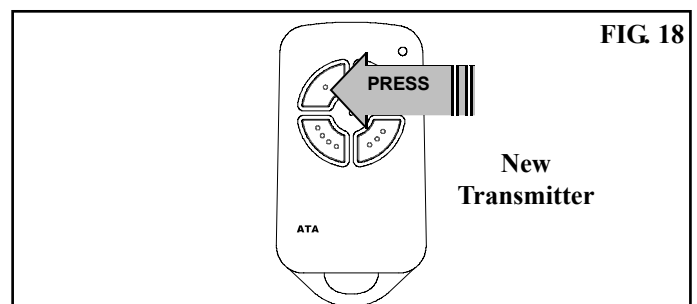
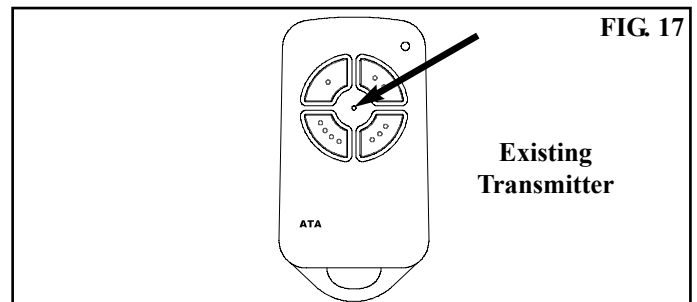
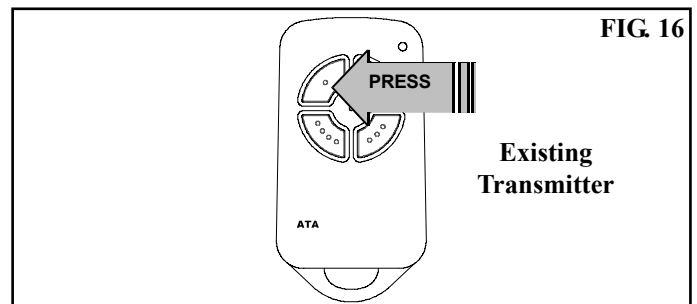
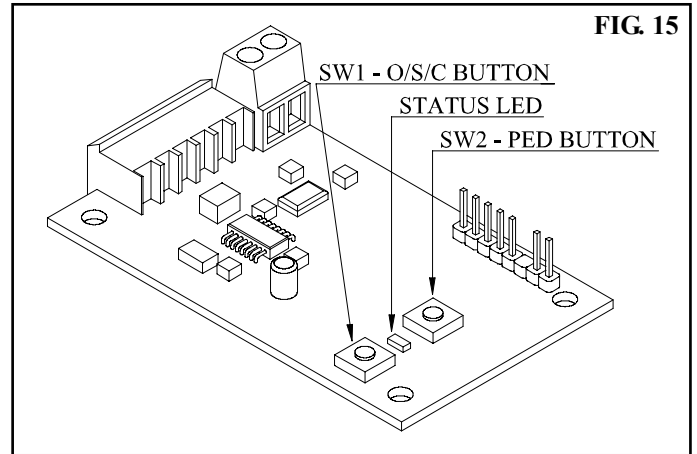

### TO DELETE ALL TRANSMITTERS

1. Turn off mains power at the switch - if the battery backup is connected, remove the VAC shunt (replace after step 4).
2. Press and hold the SW1 button on the receiver.
3. Turn on the mains power and continue to hold the SW1 button until status LED illuminates.
4. Press any transmitter button to confirm it does not operate the gate.

# ACCESSORIES

## CONTROL AND SAFETY INPUT TERMINALS

**Fig. 19** shows the control and safety input terminals and their switch contacts. Note that the P.E., OPN and STP inputs require a normally closed contact, which is provided by the shunts (**Fig. 14 and Fig. 19**). The appropriate shunt must be removed when the P.E, OPN or STP inputs are used. The CLS, OSC and PED inputs require a normally open momentary contact.

ATA Photo Electric Beam - Order Code: 90214

## LOCK RELEASE OUTPUT FOR SOLENOID LOCKS

**Fig. 20** shows how to connect an electric solenoid lock to the control board's lock release output. Note the lock release output only switches the applied voltage to the lock and must be "wetted" with the appropriate voltage.

ATA Electric Pulse Lock - Order Code: 90101.

## LOCK RELEASE OUTPUT FOR MAGNETIC LOCKS

**Fig. 21** shows how to connect an electromagnetic lock to the control board's lock release output. Note the lock release output only switches the applied voltage to the lock and must be wetted with the appropriate voltage (24V DC in the example shown).

**Note:** The lock is connected to the normally closed contact of the lock release output as the lock is energised when the controller is idle and not driving the motors. The lock output action has to be programmed for a hold action when this type of lock is used.

## LIGHT CONTROL RELAY MODULE

**Fig. 22** shows how to connect the optional relay module to the control board's connector. It also shows how to wire a light to the relay module. Any voltage relay can be used provided the relay module is able to switch the required voltage and current. Make sure any mains voltage lighting is properly earthed.

ATA Light Relay Module - Order Code: 90111.

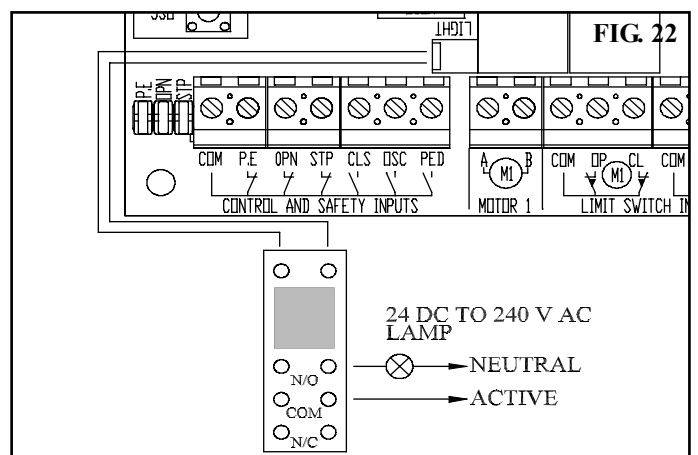
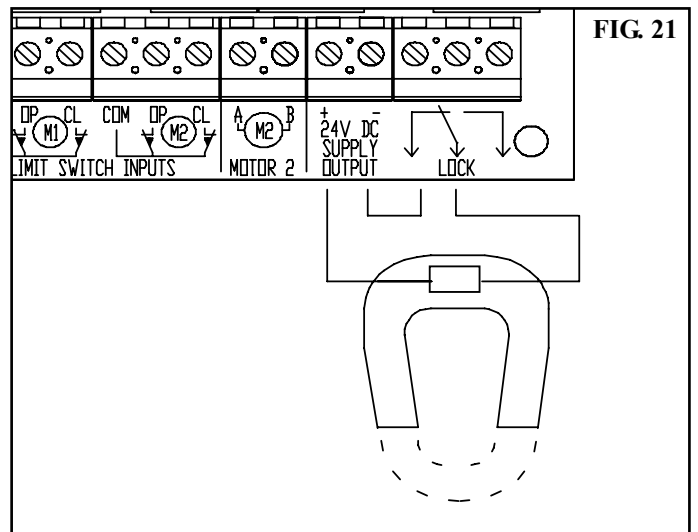
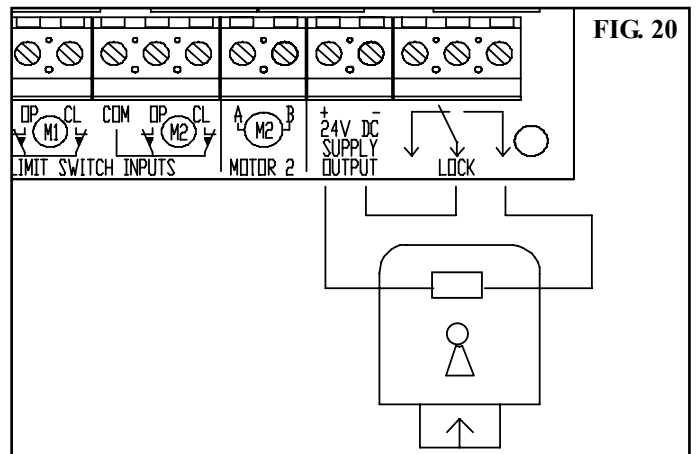
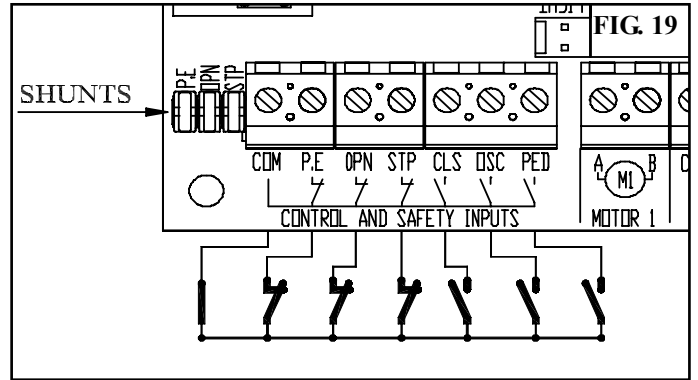

# BATTERY BACK UP

An optional battery backup system is available so that the gate can be operated (for a limited time) in the event of mains power failure. When the backup system is utilised, the control board detects the presence of mains voltage. If mains power fails the control board switches to the backup supply provided by a 24V DC battery. When mains power is restored the control board switches back to mains supply.

The following items are required to use the battery backup system:

1. A 24VDC battery connected to the control board connector (Fig. 23). ATA order code 90230
2. Ensure a shunt is placed on the VAC pins.

The control board has a built in charger which maintains the battery charge when mains power is present. The control board monitors the battery voltage during use and prevents discharging, which damages the battery, by shutting down the control board if the battery voltage gets too low.

The 'IN USE' indicator illuminates when mains is not present and the battery is being used.

The 'VAC' shunt can be removed to prevent the battery system being used when mains power fails. The battery charge is still maintained provided mains is present. This link is provided so that the controller can be turned off when a backup battery is connected. It is removed when complete absence of power is required e.g. when clearing the receivers memory.

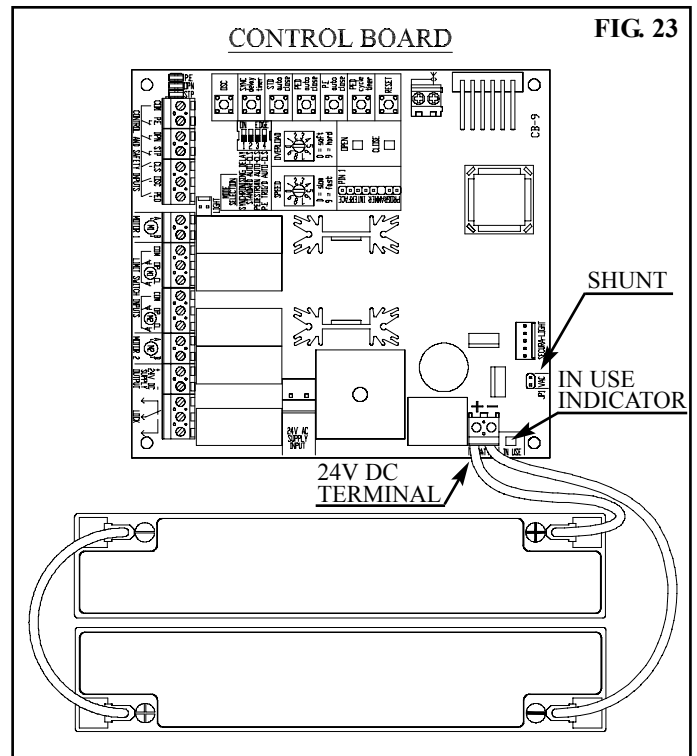

## OPERATING INSTRUCTIONS

### OPERATING THE GATE OPENER - O/S/C

- Press the Button on the Transmitter programmed for full gate opening for two seconds to open or close the gate.
- Pressing the Transmitter Button again during operation will cause the gate to stop.
- Pressing the button again will cause the gate to move in the opposite direction.

### OPERATING THE GATE OPENER - PED

- Press the button on the transmitter programmed for pedestrian access and the gate will open partially. Or in a dual leaf gate installation - only one leaf will open.
- Press the button again and the gate will close.

When an Auto Close mode selection switch is "ON" the gate will auto close after 15 – 30 seconds or as triggered by breaking the P.E. Beam and commencing the timer.

### MANUAL OPERATION

- Remove black drive unit cover (key required).
- Disengage drive motor by pulling manual release pin up using the release ring.
- While holding the ring, rotate the motor assembly clockwise.

To re-engage rotate motor assembly anti-clockwise until manual release pin clicks into place.

### OBSTRUCTION DETECTION SAFETY SYSTEM

If the gate is obstructed while closing it will reverse to the open position and when the gate is opening the gate will stop.

**NOTE:** Closing and opening obstruction forces should be checked regularly and any necessary adjustments made.

### CARING FOR TRANSMITTERS

- Do not leave transmitter in direct sunlight
- Do not expose transmitter to excessive heat
- Do not immerse transmitter in water - it is not water resistant.
- Do not subject transmitter to shock or vibration
- Keep transmitter out of reach of children at all times.

### ROUTINE MAINTENANCE

ATA recommend to grease all internal drive gears with a high pressure lubricant at 12 monthly intervals. Failure to provide routine maintenance will shorten the openers serviceable life.

### SERVICE

For on site service and assistance contact your gate/opener installer or local ATA dealer. They will be able to inspect and service both your gate and opener. Write the details of your installer in the space provided on Page 23.

# TROUBLE SHOOTING

<b>Gate does not open or close</b>	<p>Check that power is still available at mains power point.</p> <p>Check that Control Box is plugged into mains power</p> <p>Check that motor is engaged for automatic operation.</p> <p>Check all wiring from motor and microswitches to the control board are sound.</p>
<b>Gate reverses while closing or stops while opening</b>	<p>Check obstruction overload sensitivity adjustment</p> <p>Check for obstructions.</p> <p>Disengage the drive unit to manual and check the gate is in good working order.</p> <p>If a P.E. beam is fitted ensure it is clear of obstructions or dirt on the lens.</p>
<b>Transmitter not functioning</b>	<p>New transmitters must be coded to the receiver.</p> <p>Check/change the battery in the transmitter (LED flashes to indicate low battery).</p> <p>Having the antenna behind a structure (gate or fence) or not in line of sight may reduce optimal range/reception.</p> <p>Interference from external/outside sources such as baby monitors, or radio transmitter etc. The best solution is to remove the source causing the interference.</p>
<b>Gate and/or opener requires service</b>	<p>Contact the installer of the opener or local ATA dealer for service. They will be able to inspect, service, adjust or repair the gate and opener as necessary.</p>

# SPECIFICATIONS

## CONTROL BOX

<b>PROTECTION RATING:</b>	IP56
<b>INPUT VOLTAGE:</b>	230V- 240V AC 50Hz
<b>TRANSFORMER PRIMARY VOLTAGE:</b>	230V / 240VAC
<b>SECONDARY VOLTAGE:</b>	24V AC 100 VA
<b>CONTROLLER VOLTAGE:</b>	24V DC
<b>RECEIVER TYPE:</b>	UHF 433.92 MHz. AM Receiver
<b>RECEIVER CODE STORAGE CAPACITY:</b>	30 x 4 Button Transmitter Codes
<b>TRANSMITTER FREQUENCY:</b>	433.92 MHz
<b>CODING TYPE:</b>	SecuraCode® Hopping Code
<b>No. of CODE COMBINATIONS:</b>	Over 4.29 Billion Random Codes
<b>CODE GENERATION:</b>	Non-linear Encryption Algorithm
<b>TRANSMITTER BATTERY:</b>	A23 Alkaline 12 Volts
<b>DIMENSIONS:</b>	190W x 240H x 100D (mm)
<b>WEIGHT:</b>	4Kg

## DRIVE UNIT

<b>MOTOR TYPE:</b>	Permanent Magnet Direct Current
<b>MOTOR VOLTAGE:</b>	24V DC
<b>MAXIMUM PULLING FORCE:</b>	200N (20Kg)
<b>DRIVE ARM ROTATION SPEED:</b>	approx. 8°/sec
<b>DIMENSIONS:</b>	135W x 290H x 230D (mm)
<b>WEIGHT:</b>	13Kg (incl. arms)

### Note:

1. The maximum weight gate that the opener can be installed on 250Kg. The gate must be well balanced. A person of limited strength should be able to move the gate manually with very little effort (15Kg force max.) in case of an emergency.
2. Intermittent operations may occur in areas which experience very strong wind gusts. A strong wind puts extra pressure on the gate which may in turn trigger the safety obstruction detection system intermittently.

# PARTS LIST

ITEM NO.	DESCRIPTION	ORDER CODE NO.	DESCRIPTION	ORDER CODE NO.
1	SPRING WASHER ID 6	0724	DRIVE SHAFT ASSY NTA-815	04500
2	HEX NUT M4	10890	SPRING WASHER ID 6	10960
3	INT. LATCH LOCK WASHER ID 4	1140	COVER SCREW	10440
4	TAPTITE SCREW M3x16	10550	COVER SCREW	10440
5	MODIFIED ENCLOSURE GW 44 288	04880	COVER SCREW	10440
6	TRANSFORMER 05543 240/24V	05543	COVER SCREW	10440
7	WASHER C-LOC	05543	COVER SCREW	10440
8	DRIVER CRD CX ASSY V2 360-1	05641	COVER SCREW	10440
9	WASHER C-LOC	05543	COVER SCREW	10440
10	DRIVER CRD CX ASSY V2 360-1	05641	COVER SCREW	10440
11	DANGER LABEL (NEW)	13504	COVER SCREW	10440
12	ATA ADDRESS LABEL WITHOUT LOGO	05962	COVER SCREW	10440
13	RECEIVER RX-2 V2-02	10338	COVER SCREW	10440
14	RECEIVER RX-2 V2-02	10338	COVER SCREW	10440
15	HEX HEAD SCREW M6x55	10320	COVER SCREW	10440
16	FLAT WASHER 107D 6x20x5x16	07575	COVER SCREW	10440
17	FLAT WASHER 107D 6x20x5x16	07575	COVER SCREW	10440
18	FLAT WASHER 107D 6x20x5x16	07575	COVER SCREW	10440
19	FLAT WASHER 107D 6x20x5x16	07575	COVER SCREW	10440
20	FLAT WASHER 107D 6x20x5x16	07575	COVER SCREW	10440
21	FLAT WASHER 107D 6x20x5x16	07575	COVER SCREW	10440
22	FLAT WASHER 107D 6x20x5x16	07575	COVER SCREW	10440
23	FLAT WASHER 107D 6x20x5x16	07575	COVER SCREW	10440
24	FLAT WASHER 107D 6x20x5x16	07575	COVER SCREW	10440
25	FLAT WASHER 107D 6x20x5x16	07575	COVER SCREW	10440
26	FLAT WASHER 107D 6x20x5x16	07575	COVER SCREW	10440
27	FLAT WASHER 107D 6x20x5x16	07575	COVER SCREW	10440
28	FLAT WASHER 107D 6x20x5x16	07575	COVER SCREW	10440
29	FLAT WASHER 107D 6x20x5x16	07575	COVER SCREW	10440
30	FLAT WASHER 107D 6x20x5x16	07575	COVER SCREW	10440
31	FLAT WASHER 107D 6x20x5x16	07575	COVER SCREW	10440

ITEM NO.	DESCRIPTION	ORDER CODE NO.	DESCRIPTION	ORDER CODE NO.
32	FLAT WASHER 107D 6x20x5x16	07575	COVER SCREW	10440
33	FLAT WASHER 107D 6x20x5x16	07575	COVER SCREW	10440
34	FLAT WASHER 107D 6x20x5x16	07575	COVER SCREW	10440
35	FLAT WASHER 107D 6x20x5x16	07575	COVER SCREW	10440
36	FLAT WASHER 107D 6x20x5x16	07575	COVER SCREW	10440
37	FLAT WASHER 107D 6x20x5x16	07575	COVER SCREW	10440
38	FLAT WASHER 107D 6x20x5x16	07575	COVER SCREW	10440
39	FLAT WASHER 107D 6x20x5x16	07575	COVER SCREW	10440
40	FLAT WASHER 107D 6x20x5x16	07575	COVER SCREW	10440
41	FLAT WASHER 107D 6x20x5x16	07575	COVER SCREW	10440
42	FLAT WASHER 107D 6x20x5x16	07575	COVER SCREW	10440
43	FLAT WASHER 107D 6x20x5x16	07575	COVER SCREW	10440
44	FLAT WASHER 107D 6x20x5x16	07575	COVER SCREW	10440
45	FLAT WASHER 107D 6x20x5x16	07575	COVER SCREW	10440
46	FLAT WASHER 107D 6x20x5x16	07575	COVER SCREW	10440
47	FLAT WASHER 107D 6x20x5x16	07575	COVER SCREW	10440
48	FLAT WASHER 107D 6x20x5x16	07575	COVER SCREW	10440
49	FLAT WASHER 107D 6x20x5x16	07575	COVER SCREW	10440
50	FLAT WASHER 107D 6x20x5x16	07575	COVER SCREW	10440
51	FLAT WASHER 107D 6x20x5x16	07575	COVER SCREW	10440
52	FLAT WASHER 107D 6x20x5x16	07575	COVER SCREW	10440
53	FLAT WASHER 107D 6x20x5x16	07575	COVER SCREW	10440
54	FLAT WASHER 107D 6x20x5x16	07575	COVER SCREW	10440
55	FLAT WASHER 107D 6x20x5x16	07575	COVER SCREW	10440
56	FLAT WASHER 107D 6x20x5x16	07575	COVER SCREW	10440
57	FLAT WASHER 107D 6x20x5x16	07575	COVER SCREW	10440

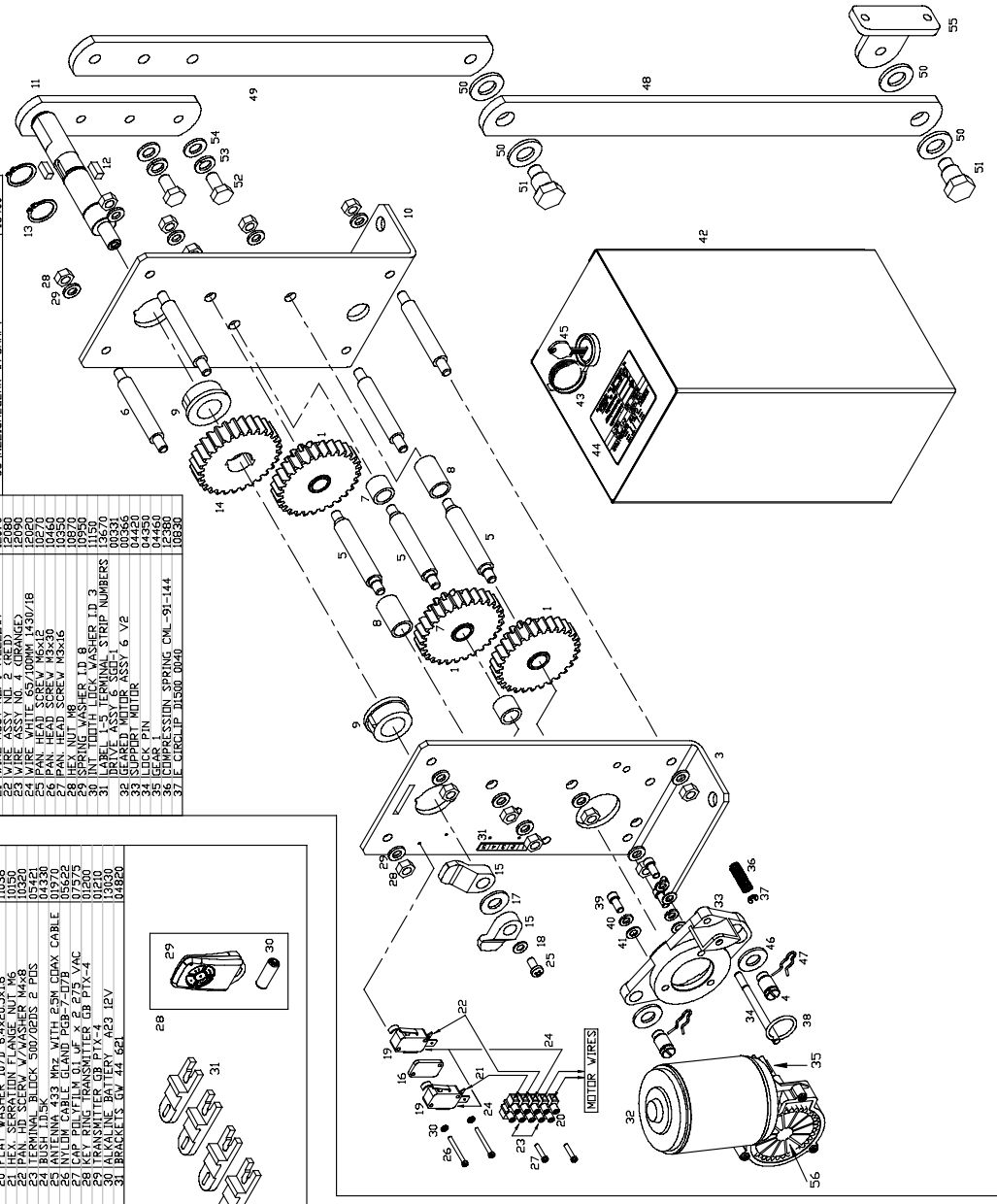
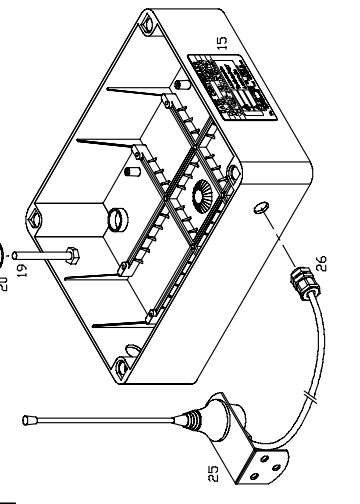
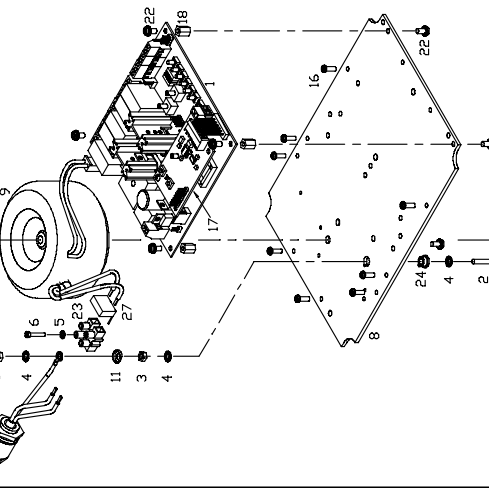
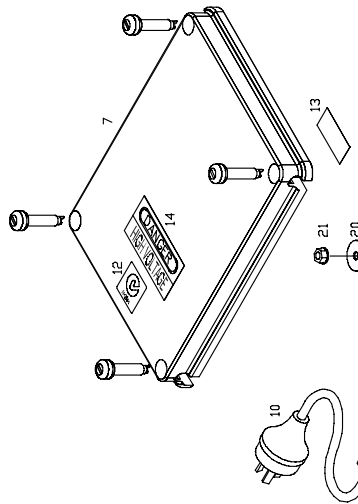
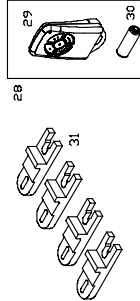

**WHEN ORDERING SPARE PARTS PLEASE QUOTE THE ORDER CODE NUMBER TO YOUR YOUR INSTALLER/DEALER**

# WARRANTY AND EXCLUSION OF LIABILITY

1. This warranty is an addition to any non-excludable conditions or warranties that are implied into this contract by relevant statute, including the Trade Practices Act 1974 (Cth).
2. Subject to all of the matters set out below, Automatic Technology Australia Pty Ltd ("ATA") warrants:
  - (a) swing and sliding gate opener drive units for twelve (12) months or 2500 cycles, whichever occurs first;
  - (b) roll-up and overhead door opener drive units for twenty four (24) months or 5000 cycles, whichever occurs first; and
  - (c) all components and accessories for twelve (12) months, from the date of purchase (specified in the sales docket receipt) as free of any defects in material and workmanship.
3. This warranty applies only where the purchaser:
  - (a) immediately notifies ATA or the retailer of the alleged defect;
  - (b) returns the product to the retailer; and
  - (c) presents the relevant sales docket and this warranty document to the retailer to confirm the date of purchase.
4. Except for this warranty, ATA gives no warranties of any kind whatsoever (whether express or implied), in relation to the product, and all warranties of whatsoever kind relating to the product are, to the extent permissible by statute, hereby excluded.
5. To the extent permissible by statute, ATA disclaims any liability of whatsoever nature in respect of any claim or demand for loss or damage which arises out of:
  - a) accidental damage to or normal wear and tear to the product or to the product's components;
  - b) any cost relating to damage resulting from wear and tear;
  - c) blown fuses, loss or damage caused by electrical surges, power surges or power spikes;
  - d) loss or damage due to theft, fire, flood, rain, water, lightning, storms or any other acts of God;
  - e) maximum continuous operating time exceeding one (1) minute in ten (10);
  - f) maximum operating force exceeding 15Kg (150N) when moving the door or gate manually to the open or closed position;
  - g) door surface area and/or weight exceeding 15m<sup>2</sup> and 100Kg respectively;
  - h) residential gate weight exceeding 400Kg;
  - i) door or gate not in safe and correct working order and condition;
  - j) evidence of unauthorised repairs;
  - k) any cost relating to damage caused by misuse, negligence or failure to maintain the equipment in a proper working order as per clauses (d) through (i);
  - l) installation, adjustment or use which is not in accordance with the instructions set out in installation instruction manual;
  - m) attempted or complete modification or repairs to the product carried out by a person who is not authorised or has not been trained by ATA to carry out such modification or repairs;
  - n) faulty or unsuitable wiring of structure to which the product is fixed or connected;
  - o) radio (including citizen band transmission) or any electrical interference;
  - p) damage caused by insects;
  - q) loss or damage to any property whatsoever or any loss or expense whatsoever resulting or arising there from or any consequential loss;
  - r) any cost or expense arising due to manufacturer recall of any product;
  - s) any cost or expense due to negligence of the approved service provider;
  - t) installation of a residential garage door or gate opener in a commercial or industrial situation or a non-single residential dwelling.
6. ATA's liability under this warranty is limited, at ATA's absolute option, to replacing or repairing the product which ATA, in its unfettered opinion, considers to be defective either in material and/or workmanship or to credit the dealer with the price at which the product was purchased by the dealer.
7. This warranty does not extend to cover labour for installation.
8. This warranty is limited to Return-to-Base (RTB) repair and does not cover labour for on-site attendance.
9. This warranty is void if the Product is not returned to the manufacturer in original or suitably secure packaging.
10. This warranty is only applicable for repairs to the product carried out within Australia.
11. This warranty does not cover consumable items including globes, batteries and fuses.
12. This warranty is not transferable.
13. Where the Product is retailed by any person other than ATA, except for the warranty set out above, such person has no authority from ATA to give any warranty or guarantee on ATA's behalf in addition to the warranty set out above.

## Notes:

1. One (1) cycle = one (1) open and one (1) close action of the door or gate.
2. This warranty is to be read in conjunction with the owner's copy of the installation instruction manual.

# NOTES

Purchased From \_\_\_\_\_ Phone \_\_\_\_\_

Installed By \_\_\_\_\_ Date \_\_\_\_\_

Serial No. \_\_\_\_\_

**AUTOMATIC TECHNOLOGY AUSTRALIA PTY LTD**

ABN 11 007 125 368

17-19 Advantage Rd, Highett, Victoria, Australia 3190

Tel: +61 3 9532 2788 Fax: +61 3 9532 2799

Web: [www.ata-aust.com.au](http://www.ata-aust.com.au) Email: [sales@ata-aust.com.au](mailto:sales@ata-aust.com.au)